

C-Series High Power Laser Diode Module

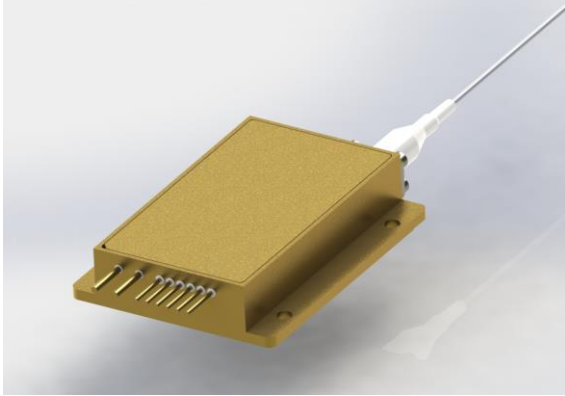

- Features**
- ◆ High output power of 30W
 - ◆ 105µm/0.22NA multimode optical fiber
 - ◆ Center wavelength 793±3nm
- Applications**
- ◆ Fiber laser pumping
 - ◆ Direct diode laser applications

Package Dimensions (mm)

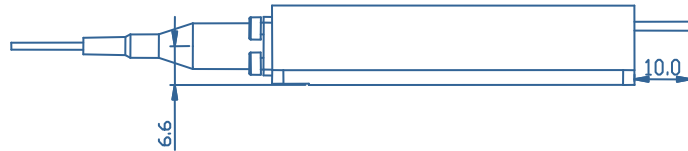
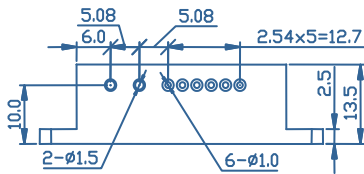

Pin-Out Assignment	
Pin	Function
1	LD (+)
2	LD (-)
3	-
4	-
5	-
6	-
7	-
8	-

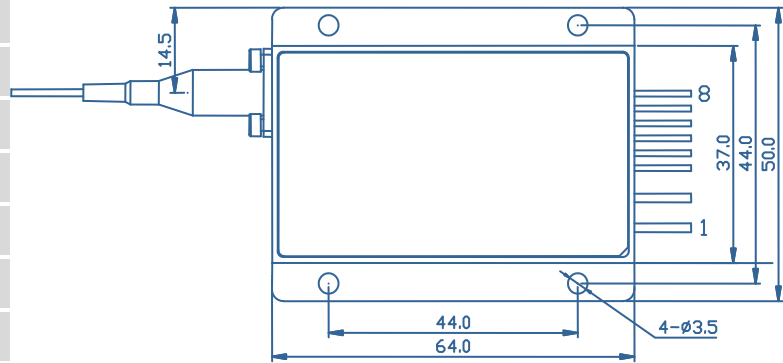

Typical Device Performance (25°C)

	Min	Typical	Max	Unit
Optical				
CW Output Power	-	30	-	W
Center Wavelength	-	793±3	-	nm
Spectral Width (FWHM)	-	<3.0	-	nm
Wavelength Shift with Temperature	-	0.3	-	nm /°C
Feedback Protection (1800-2100nm)	-	30	-	dB
Electrical				
Threshold Current	-	0.7	-	A
Operating Current	-	6	-	A
Operating Voltage	-	11.3	-	V
Slope Efficiency	-	5.7	-	W / A
Power Conversion Efficiency	-	44	-	%
Fiber*				
Fiber Core Diameter	-	105	-	μm
Fiber Cladding Diameter	-	125	-	μm
Fiber Buffer Diameter	-	250	-	μm
Numerical Aperture	-	0.22	-	-
Fiber Length	-	1-5	-	m
Fiber Connector	-	-	-	-

* Customized fiber and connector available.

Absolute Ratings

	Min	Max	Unit
Operating Temperature	10	40	°C
Operating Relative Humidity	-	75	%
Storage Temperature	-20	80	°C
Storage Relative Humidity	-	90	%
Lead Soldering Temperature (10 s max)	-	250	°C